



**Thermo Scientific
ROTARY MICROTOME
Microm HM 340 E

INSTRUCTION MANUAL**

Thermo Scientific Rotary Microtome Microm HM 340 E

CERTIFICATION

Thermo Fisher Scientific Microm International GmbH certifies that this instrument has been tested and checked carefully. Its technical data was verified before shipment to be in accordance with the published specifications.

The instrument complies with applicable international safety regulations.



WARRANTY

This product is warranted against defects in material and workmanship for a period of 1 year. Parts which prove to be defective during the warranty period will be repaired or replaced free of charge by Thermo Fisher Scientific Microm International GmbH. No other warranty is expressed or implied. Unauthorized modification or repair by third party persons will void the warranty. The warranty will expire in case of improper or wrong use of the instrument and in case the warning and precautionary messages are not observed. Thermo Fisher Scientific Microm International GmbH is not liable for any occurring damage.

Errors and omissions excepted. Subject to amendment and improvement without further notice.

This instruction manual will be supplied together with each instrument. Further copies can be ordered at the nearest sales office by giving the serial number of the instrument, the number of the instruction manual and the date of issue.

This instruction manual is available in the following languages:

	Cat. no.
German:	387830
English:	387831
French:	387832
Spanish:	387833
Italian:	387834

Thermo Scientific Rotary Microtome Microm HM 340 E

Dear Customer,

Thank you for buying this instrument.

Before putting the instrument into operation, please read these operating instructions carefully to familiarize yourself with its proper operation and functions. To avoid risks for the operator and technical damage to the instrument, it must only be used in accordance with its intended use (see part 1-2).

Any other use of the instrument is considered improper! All warranties and guarantees would then be null and void.

Only skilled or specially trained personnel must operate the microtome, i.e. clamping the specimen, trimming and first-cuts, sectioning and transferring sections onto a slide. The listed and marked safety measures as well as the regulations and hygiene measures of your respective lab must strictly be observed.

Serial number:

Please check the Ser. No. on the type plate, which is placed on the rear side of your instrument and enter this number here. This way, questions and service can be handled faster.

Instruction manual no. 387831

Issued on March 15th, 2011

Microm International GmbH part of Thermo Fisher Scientific Otto-Hahn-Str. 1A
--

69190 Walldorf Germany

Phone:	+49.(0)6227.836-0
Fax:	+49.(0)6227.836-111
Email:	info.dxd.dewal@thermofisher.com
Internet:	www.thermoscientific.com

Table of contents

PART 1 IMPORTANT INFORMATION

- 1-1 Safety precautions and symbols
- 1-2 Intended use

PART 2 INTRODUCTION

- 2-1 Description Rotary Microtome HM 340 E
- 2-2 Accessories
 - 2-2-1 Standard equipment
 - 2-2-2 Additional equipment (optional)
- 2-3 Technical data Rotary Microtome HM 340 E

PART 3 OPERATING INSTRUCTIONS

- 3-1 Setting up the microtome
- 3-2 Initial turn-on
 - 3-2-1 Operating panel
- 3-3 Display and key functions
 - 3-3-1 Indication of cutting processes
 - 3-3-1-1 Section counter
 - 3-3-1-2 Section thickness sum
 - 3-3-1-3 Remaining travel to front end position
- 3-4 Setting section thickness and trimming thickness
 - 3-4-1 Trimming and first cuts
 - 3-4-2 Fine feed
- 3-5 Cutting movement and retraction
- 3-6 Locking and unlocking the handwheel
- 3-7 Feed
 - 3-7-1 Specimen coarse feed and speed for coarse feed
- 3-8 Menu
 - 3-8-1 Date and time
 - 3-8-2 Display mode
 - 3-8-3 Turning off the function "Retraction"
 - 3-8-4 Language selection for the display
- 3-9 Adapters for specimen clamping
 - 3-9-1 Adapter, non-orienting
 - 3-9-2 Adapter, orienting, specimen orientation
 - 3-9-3 Clamping and/or changing specimen clamps
 - 3-9-4 Readjusting specimen clamps

Thermo Scientific Rotary Microtome Microm HM 340 E

- 3-10 Specimen clamping
 - 3-10-1 Universal cassette clamp
 - 3-10-2 Universal cassette clamp, adjustable
 - 3-10-3 Standard specimen clamp
 - 3-10-4 Insert for round specimen clamps, V insert and V distance piece
 - 3-10-5 Foil clamp
 - 3-10-6 Segment arc and universal specimen holder

- 3-11 Knife carrier
 - 3-11-1 Disposable blade carrier ER
 - 3-11-2 Disposable blade carrier E
 - 3-11-3 Knife carrier C
 - 3-11-4 Readjusting the knife carrier

- 3-12 Section waste tray

- 3-13 Memory function

- 3-14 Large field magnifier

PART 4 WORKING WITH THE MICROTOME

- 4-1 Sectioning instructions
- 4-2 How to avoid malfunctions
- 4-3 Possible sources of errors – cause and removal

PART 5 MAINTENANCE AND CARE

- 5-1 Cleaning and care
- 5-2 Maintenance
- 5-3 Replacement work

PART 6 CONDITIONS FOR THE TRANSPORTATION OF THE INSTRUMENT

- 6-1 Returning the instrument for repair and routine maintenance
- 6-2 Disposal of the instrument after final shutdown

PART 1 IMPORTANT INFORMATION

1-1 WARNING SIGNALS AND SYMBOLS

The installation and routine use of the HM 340 E is easy and safe if the instructions in this manual are being observed.



Note:

Special instructions regarding operation of the instrument.



Warning:

Special precautionary measures to prevent damage to equipment. For a long lifetime of the equipment, please observe these instructions carefully.



Caution – general danger spot:

The instruction manual must strictly be observed whenever this symbol is visible on the instrument.



Hazard of hand injuries:

Due to moving parts in connection also with the microtome knife, a danger area arises, which might lead to hand injuries in case of non-compliance with the safety features of the microtome and when disregarding the instruction manual.



Biohazard:

Warning of biological danger.



Radioactivity:

Warning of radioactive danger.



Chemicals :

Warning of unhealthy or irritating substances.



Separate taking back of electrical and electronic instruments in the countries of the European Union:

This is to be applied in the countries of the European Union and other European countries with a separate collecting system within the waste management.

This product, being an electro and/or electronic instrument, must be treated separately within the waste management process (WEEE).

SAFETY PRECAUTIONS AND IMPORTANT INFORMATION

CAUTION!

The operator's safety is affected, when the instrument is not operated in accordance with this instruction manual.

Please observe the following general precautions during operation of this instrument. Failure to comply with these precautions violates safety standards and the intended use of the instrument.

Thermo Fisher Scientific Microm International GmbH is not liable for misuse of the instruments and failure to comply with basic safety requirements.

INSTRUMENT GROUNDING

To avoid injury from electrical current, the instrument must be connected with the protective earth. The instrument is equipped with a three wire ground plug. The power outlet must be connected to the protective earth and must meet the International Electrotechnical Commission (IEC) regulations.

CAUTION: MAINS VOLTAGE

Never remove instrument covers during operation. Component replacements as well as adjustments must only be made by trained service personnel. Only use original spare parts for replacement work. Unplug the unit before removing or opening the covers.

CARE IN USING MICROTOME KNIFE



To diminish the danger of being injured by the knife or blade, use the knife guard when adjusting specimen and knife. If possible, the specimen should be clamped in before the knife is inserted into the knife holder. Before changing the knife holder, always remove blade or knife! Unused knives should always be kept in a knife case. Never place the knife with the cutting edge upwards. Never try to catch a dropping knife!! Never check the sharpness of the cutting edge with your fingers. The cutting edge is extremely sharp!

HAZARD OF RADIOACTIVE RADIATION



When working with radioactive specimens observe all applicable radiation safety procedures. When working with radioactive contaminated material, appropriate safety and disinfection measures must be carried out. According to the rules and regulations concerning the handling of radioactive contaminated material of the respective laboratory, safety clothing (e.g. particle mask, gloves, protective shoe covers) must be worn. Radioactive contaminated waste must be disposed of according to the respective regulations.

HAZARD OF INFECTION



Specimens used during the intended operation of the instrument might potentially be infectious. For this reason, it is recommended to observe the general laboratory regulations concerning protection against danger of infection.

Information on decontamination media, their use, dilution and effective range of application can be read in the Laboratory Biosafety Manual : 1984 of the World Health Organization.

When working with infectious specimens observe all applicable safety procedures. When working with infectious material, appropriate safety and disinfection measures must be carried out. According to the rules and regulations concerning the handling of infectious material of the respective laboratory, safety clothing (e.g. particle mask, gloves, protective shoe covers) must be worn. Infectious waste must be disposed of according to the respective regulations.

WASTE DISPOSAL

All debris, waste as well as infectious and radioactive contaminated material from operation must be disposed of in accordance with the respective regulations of the lab. Section waste must be disposed of according to the respective regulations for special waste.

HAZARD OF MALFUNCTION

To avoid the hazard of malfunction of an instrument, it must only be operated in a controlled electromagnetic environment. This means, that transmitters such as mobile phones must not be operated in their close vicinity.

In case of malfunctions and/or service work, please turn off the instrument and contact your local dealer.

DANGER IN EXPLOSIVE ENVIRONMENT

The instrument must not be operated in the presence of flammable gases.

1-2 INTENDED USE

The Rotary Microtome HM 340 E from Thermo Fisher Scientific Microm International GmbH is a highly efficient multi-purpose microtome which can be used for paraffin, hard- and semithin-sectioning techniques in biology, medicine, industry and research.

Only skilled or specially trained personnel must operate the microtome, i.e. clamping the specimen, trimming and first-cuts, sectioning and transferring sections onto a slide. The listed and marked safety measures as well as the regulations and hygiene measures of your respective lab must strictly be observed.



Note:

This instruction manual is part of the product. Keep it always close to the instrument!

2 INTRODUCTION

2-1 DESCRIPTION ROTARY MICROTOME HM 340 E

The Rotary Microtome HM 340 E from Thermo Fisher Scientific Microm International GmbH is a highly efficient multi-purpose microtome which can be used for paraffin, hard- and semithin-sectioning techniques in biology, medicine, industry and research.

The HM 340 E sets new ergonomical standards concerning operation and comfort. The instrument is equipped with a section waste tray with integrated arm rest, which is built around and under the knife carrier for direct collection of section waste.

This model can be equipped with all specimen clamps and knife carriers of the Rotary Microtome series. In addition, the stereomicroscope or the large field magnifier can be adapted.

The HM 340 E will cut sections in a range from 0,5 µm up to 100 µm. For the protection of knife and specimen, the instrument retracts the specimen at the end of the cut. If desired, the function <retraction> can be turned off.

The motorized coarse feed system allows the continuous specimen forward and backward travel with three different speed settings. This way, specimen and knife edge distance can be adjusted quickly.

A trimming function with defined steps from 5 µm to 500 µm permits the fine adjustment up to the first cuts and results in larger section thicknesses when trimming.

The operating panel is installed on the left side of the microtome. It can be removed and used separately. The selected section thickness, trimming thickness, section counter, sum of section thicknesses, remaining travel to the front end position as well as the current date and time are indicated on the display of the operating panel.

The knife carriers are designed so the knives can be easily clamped in place and adjusted.

In addition, the instrument is equipped with a hand wheel brake that locks in any position.

The manual rotary movement of the hand wheel of the Rotary Microtome HM 340 E is converted into a vertical movement of the cylinder head which carries the specimen holder.

Sectioning is carried out by knives or blades, which must be adjusted and fixed on the knife carrier.

With the downward movement of the specimen, sectioning is carried out (cutting movement).

The upward return travel of the specimen is carried out by turning the hand wheel further in clockwise direction. During this return travel, the specimen is drawn back to protect knife and specimen. If desired, the function <retraction> can be turned off. The selected section thickness is delivered at the upper reversal point of the return travel.

The number of the sections made can be shown on the section counter on the display. After each downward movement of the specimen holder, the number on the section counter increases by 1. The sum of the sections carried out can also be seen on the display. For this, trimming values and sectioning values are added up. Section counter and sum of section thicknesses can be reset to zero at any time by means of the RESET-button.

Moreover, the remaining travel to the front end position can also be shown on the display. The remaining travel, which is still available for sectioning, is shown in microns. If the specimen holder is in the back end position, the display shows 28 000 µm. This number decreases, the further the specimen holder is moved towards the front.

The fast freezing unit K-34 allows frozen sectioning with the specimen temperature as low as -45°C.

Total overview

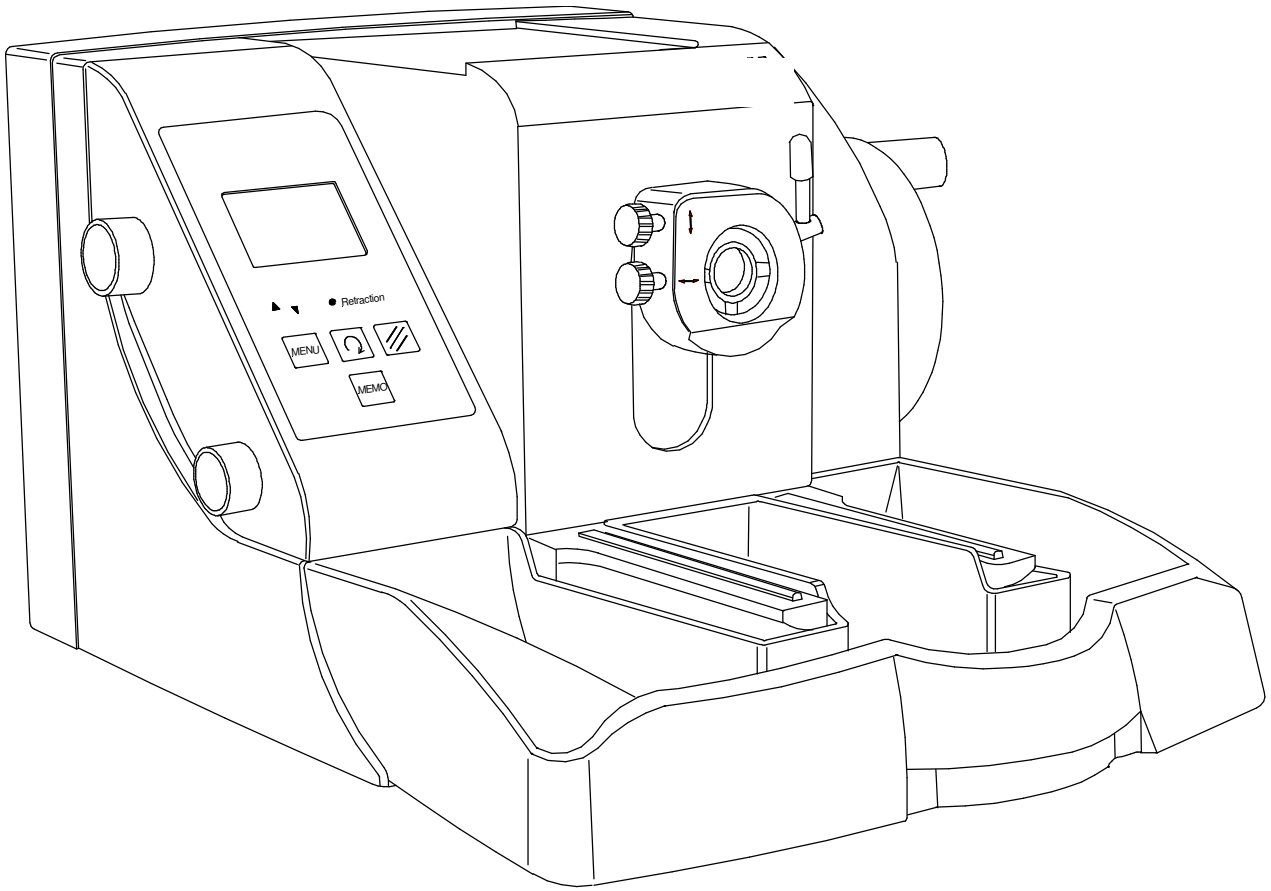

Fig. 1

2-2 ACCESSORIES

2-2-1 STANDARD EQUIPMENT

The Rotary Microtome HM 340 E is supplied with the following accessories:

- 1 Hex head wrench 6 mm
- 1 Cover
- 1 Para Gard, 100 ml
- 1 Instruction manual
- 2 Cover plates

2-2-2 ADDITIONAL EQUIPMENT (OPTIONAL)

2-2-2-1 KNIFE CARRIER

Art. Nr.

Standard knife carrier N	705670
Disposable blade carrier E	705640
Disposable blade carrier ER	705650

2-2-2-2 SPECIMEN CLAMPS

Standard specimen clamp	715010
Universal cassette clamp	715020
Universal cassette clamp, adjustable	716130
Foil clamp	715030
Sandwich supporting material	176010
Insert for round specimens, Ø 6 mm	715070
Insert for round specimens, Ø 15 mm	715080
Insert for round specimens, Ø 19 mm	715280
Insert for round specimens, Ø 25 mm	715090
V-insert	715100
V-distance piece	715320

Thermo Scientific Rotary Microtome Microm HM 340 E

	Cat. no.
Segment arc	715050
Universal specimen holder	715060

2-2-2-3 OPTICAL ACCESSORIES

Large field magnifier, 220 V	760160
Large field magnifier, 120 V	760170
Stereomicroscope Stemi 2000	755210
Adapter for Stemi 2000	532090
KL 1500 with ring illumination	
230 V, 50 - 60 Hz	760280
120 V, 50 - 60 Hz	760290

2-2-2-4 MIKROTOMMESSER

Steel knives, type c	
12 cm	152010
16 cm	152020
18,5 cm	152270
22 cm	152030
Steel knives, type d	
12 cm	152060
16 cm	152070
22 cm	152080
Tungsten carbide knife, 16 cm, d	152120
Knife cases	
12 cm	152220
16 cm	152230
18,5 cm	152280
22 cm	152240
Disposable blades for paraffin	
SEC 35	152200
SEC 35e	152210

2-14-5 ADDITIONAL ACCESSORIES

Fast freezing unit K 34

100 V/50 - 60 Hz

115 V/60 Hz

230 V/50 Hz

240 V/50 Hz

Section transfer system STS

100 V/50 - 60 Hz

115 V/60 Hz

230 V/50 Hz

240 V/50 Hz

Lubricating oil, 100 ml

350110

Lubricating oil, 250 ml

350120

Paraffin repellent, PARA GARD, 100 ml

350170

Thermo Scientific Rotary Microtome Microm HM 340 E

2-3

TECHNICAL DATA HM 340 E

Microtome:	Section thickness range 0,5 - 100 µm
	Resolution 0,5 µm from 0,5 - 2 µm
 1 µm from 2 - 10 µm
 2 µm from 10 - 20 µm
 5 µm from 20 - 30 µm
 10 µm from 30 - 40 µm
 20 µm from 40 - 100 µm
	Trimming thickness range 5 - 500 µm
	Resolution 5 µm from 5 - 10 µm
 10 µm from 10 - 100 µm
 20 µm from 100 - 200 µm
 50 µm from 200 - 500 µm
	Specimen retraction during return travel 40 µm
	Horizontal feed range 28 mm
	Vertical specimen stroke 64 mm
Section counter: 5-digit, with reset
Section thickness sum: 5-digit, with reset
Remaining travel to front end position: 5-digit
Specimen size:	when using a standard specimen clamp: 55 x 50 mm
Specimen orientation:	x - and y - axes universal 8°
	rotation: up to 360°
Cutting drive: manual by means of handwheel
Coarse feed: motorized, graduated and continuous
Speed for coarse feed: 400, 800 or 1200 µm/s
Storage temperature range: -20°C up to +50°C
Operating conditions: +5°C up to +40°C (at a max. rel. humidity of 60%)
 altitude up to 2000 M.S.L.
 for indoor use only
Floor loading requirements: 103 kg
Power requirements: 220...230 V 200 mA +/-10% 50...60 Hz
 240 V 200 mA +/-10% 50...60 Hz
 100 V 400 mA +/-10% 50...60 Hz
 115 V 400 mA +/-10% 50...60 Hz
Pollution degree: 2
Overvoltage category: II
Sound pressure: 39 dB(A)
Dimensions: 410 mm x 520 mm x 280 mm (wide/deep/high)
Weight: 28 kg

3 OPERATING INSTRUCTIONS

3-1 SETTING UP THE MICROTOME

- Cut through the bands around the carton.
- Open the carton.
- Remove the accessories.
- On the lower rear side of the instrument, there is a recessed grip to lift or carry the microtome.
- Lift the microtome out of the carton.



Note:

Do not use the handwheel handles to lift or carry the instrument.

- Choose the site of installation in a way that the switch for separating the instrument from the voltage can be reached at any time.
- Place the microtome on a stable and vibration free table, as sectioning can be influenced by nearby instruments which generate vibrations.
- Handwheel and coarse feed wheel must be free and accessible in a comfortable way.
- Remove the separately packed section waste tray and install it at the base plate from the front side.
- In the rear part of the base plate, there are sliding feed for an easy moving of the microtome.
- Slightly lift the base at the front end only and slide the microtome.



Note:

Remove the section waste tray to move or carry the instrument. The section waste tray can be pulled out of its proper position.

- Before starting section, instrument, knife carrier and section waste tray should be treated with a commercially available paraffin repellent.



Note:

This medium considerably reduces the adhesive force of paraffin sections on the individual parts (see part 2-2-2-5, optional accessories).

3-2 INITIAL TURN-ON



Note:

The kind of the used examination materials and all special conditions for their processing, pre-treatment and, if necessary, storage as well as instrument controls for correct and safe operation is in the responsibility of the operator.

The operator is also responsible for special equipment and materials and/or reagents for the operation of the instrument.



Warning:

Before turning on the instrument for the first time, please check if the power requirements indicated on the type plate correspond to the power supply voltage being used.

The operating panel, which is separately packed, can be attached to the instrument or used freestanding. First connect the operating panel with the instrument:

- A control cable (fig. 3.1) is fixed on the back of the instrument.
- Connect this cable with the connector at the back of the operating panel.
- Should the operating panel be attached to the instrument, push the connector through the corresponding hole (fig. 3.2) on the back of the microtome.
- Turn the connector 90° and push it through the hole on the front of the instrument.
- Plug the connector into the operating panel. Fasten the cable on the panel with the two screws.
- To clear away the cable, insert it into the corresponding holders (fig. 3.3) on the back of the microtome.
- Connect the power cord to the power socket (fig. 3.4) on the back of the instrument.
- Turn on the power switch (fig. 3.5).
- Then, the specimen holder moves to the back end position.
- This movement is always carried out when the instrument is turned on.
- This way, the instrument is calibrated.
- Afterwards, FEED and TRIM are shown on the display.
- The insert for the two fuses is placed beside the power switch.

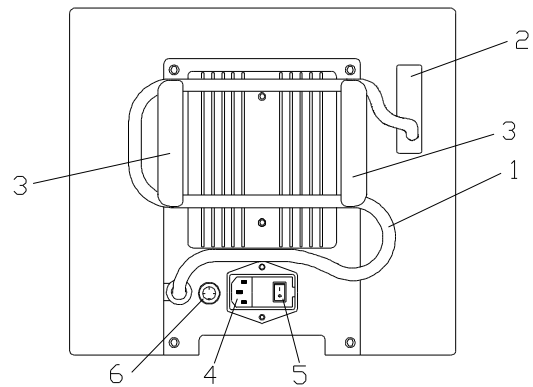

Fig. 3

3-2-1 OPERATING PANEL

The operating elements of the operating panel are easily and clearly arranged for a comfortable operation.

- The operating panel can be removed from the instrument and used separately at any time.

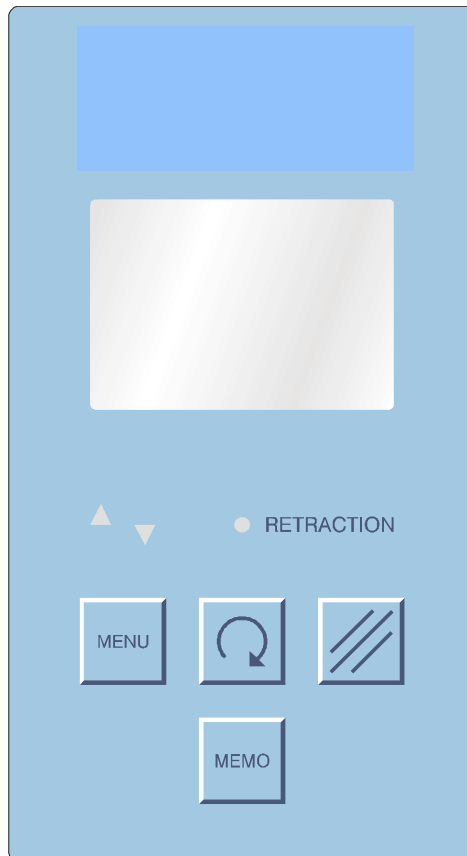

Fig. 4

3-3 DISPLAY AND KEY FUNCTIONS

3-3-1 INDICATION OF CUTTING PROCESSES

In the lower line of the display information about the sectioning status can be seen.

- Press the "scroll button" (fig. 5.1), to show the various functions one after the other on the display.

The following information on the current sectioning position of the instrument can alternatively be seen on the display:

- number of sections
- sum of section thicknesses
- remaining travel to the front end position
- date and time

- For this, press button (fig. 5.1) until the required information is shown on the display.
- If no information is required in this line, press button (fig. 5.1) until this line of the display is blank.

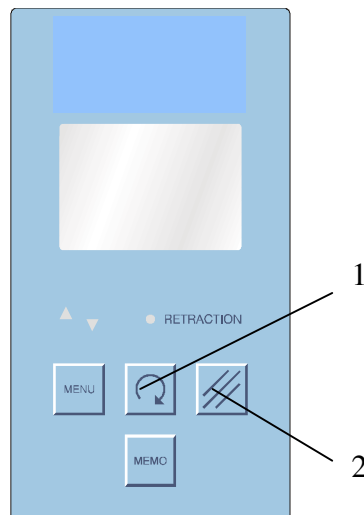

Fig. 5

3-3-1-1 SECTION COUNTER

The section counter (fig. 6) adds up the number of sections produced. After each downward movement of the specimen holder, the number on the section counter increases by 1.

- The counter can be reset to zero by means of the button (fig. 5.2).

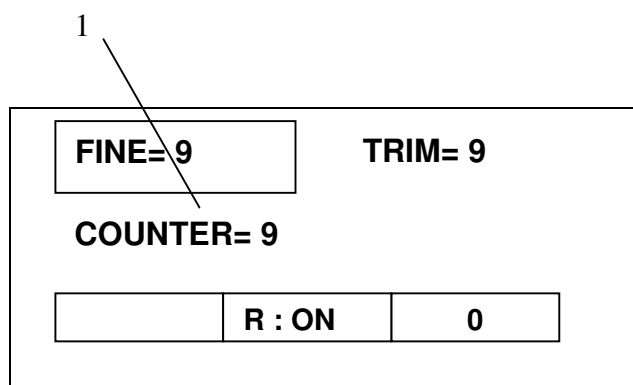

Fig. 6

3-3-1-2 SECTION THICKNESS SUM

This value shows the sum in microns of the sections already cut. Trimming values as well as sectioning values are added up (fig. 7.2).

- This value can also be reset to zero by means of the button (fig. 5.2).

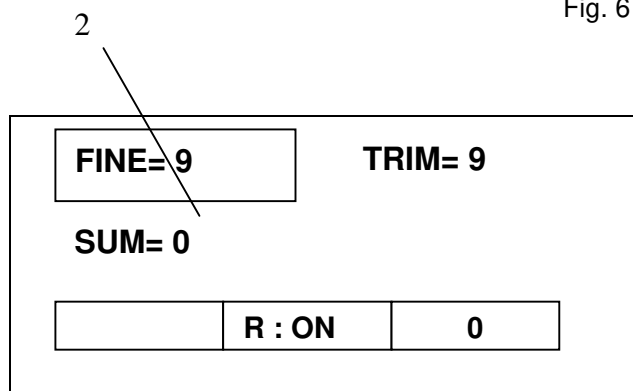
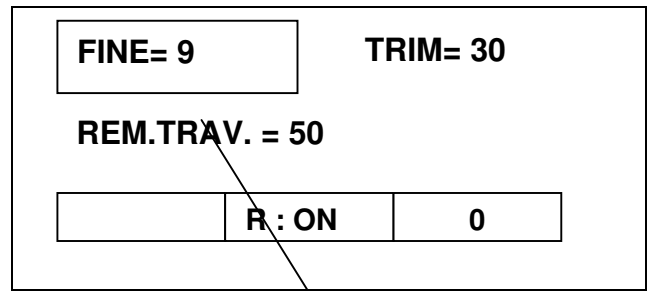

Fig. 7

3-3-1-3 REMAINING TRAVEL TO FRONT END POSITION

This value shows the distance in microns, which is left for sectioning (fig. 8.3).
If the specimen holder is in the back end position, the display shows 28 000 μm . This number decreases the closer the specimen comes towards the front.



3

Fig. 8

3-4 SETTING SECTION THICKNESS AND TRIMMING THICKNESS

- The required section and trimming thicknesses are set by means of the control knob (fig. 9.1), which is placed on the side part of the operating panel.
- To choose between section thickness and trimming thickness, press the control knob (fig. 9.1). The selected thickness range is then marked with a rim when in the operating mode NORMAL.



Note:

Whenever the instrument is turned on, "FINE" sectioning is automatically selected and shown accordingly (fig.

10.1).

FINE = pre-selected section thickness
 TRIM = pre-selected trimming thickness

The graduation of the section thicknesses is divided into six ranges:

Range:	Graduation:
up to 2 µm	0,5 µm
from 2 µm to 10 µm	1 µm
from 10 µm to 20 µm	2 µm
from 20 µm to 30 µm	5 µm
from 30 µm to 40 µm	10 µm
from 40 µm to 100 µm	20 µm

The graduation of the trimming thicknesses is divided into four ranges:

Range:	Graduation:
up to 10 µm	5 µm
from 10 µm to 100 µm	10 µm
from 100 µm to 200 µm	20 µm
from 200 µm to 500 µm	50 µm

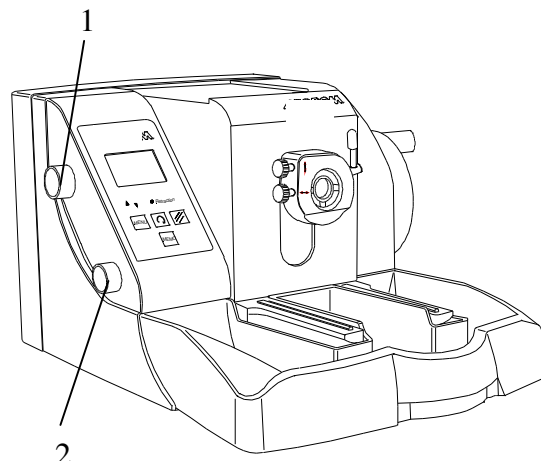

Fig. 9

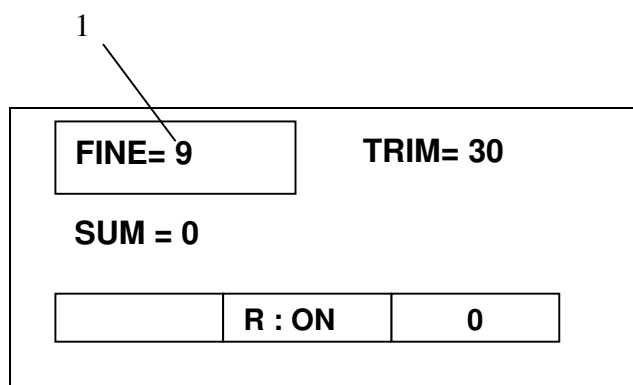

Fig. 10

3-4-1 TRIMMING AND FIRST CUTS

After the specimen and the knife are adjusted, further gradual feed for trimming can be carried out using the function "trimming". For different sectioning series, deeper layers of the specimen can be reached with the function "trimming".

- Press the operating knob for the section thickness setting (fig. 11.1) to select TRIM.
- In the operating mode NORMAL, a rim is shown on the display around the TRIM value (fig. 12.1).
- When this mode is activated, turn the knob to alter the value.
- During each handwheel rotation, the specimen holder is moved forwards by the preselected trimming value in the upper reversal point.

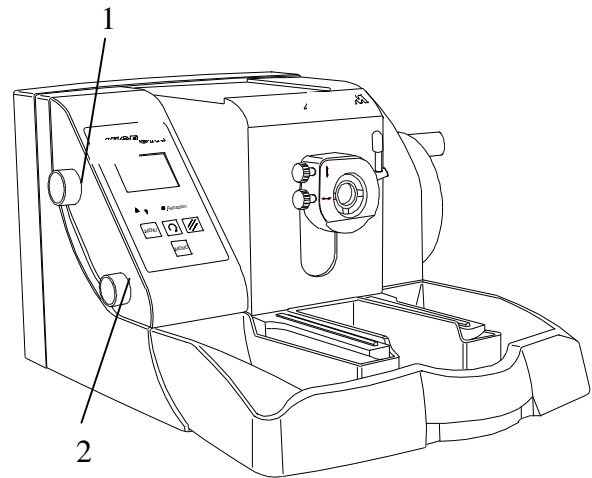

Fig. 11



Note:

In addition, press the knob for the coarse feed (fig. 11.2) a further trim feed can be released, even if the fine mode is active.

- Whenever the knob (fig. 11.2) is pressed, the specimen holder moves forwards by the trimming value which was preselected on the control knob (fig. 11.1).

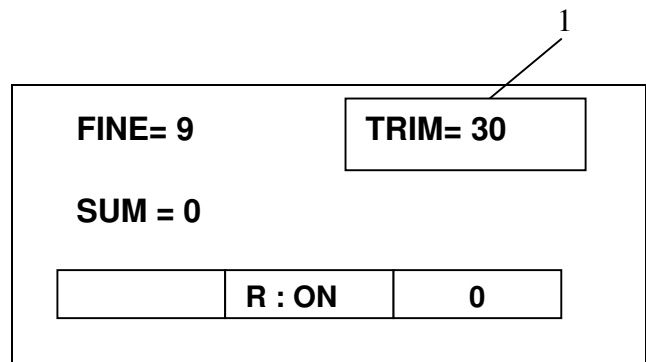

Fig. 12

3-4-2 FINE FEED

After having adjusted knife and specimen as well as having trimmed the specimen, sectioning can be started.

- Press the control knob (fig. 13.1) to select the fine section thickness setting.
- In the operating mode NORMAL, a rim is shown on the display around the FINE value (fig. 14.1).
- When this mode is activated, turn the knob to alter the value.
- Turn the handwheel in a clockwise direction to feed the specimen at the selected section thickness.
- The same process is carried out when the motor drive for the cutting movement is turned on.
- The handwheel on the right side of the instrument rotates.

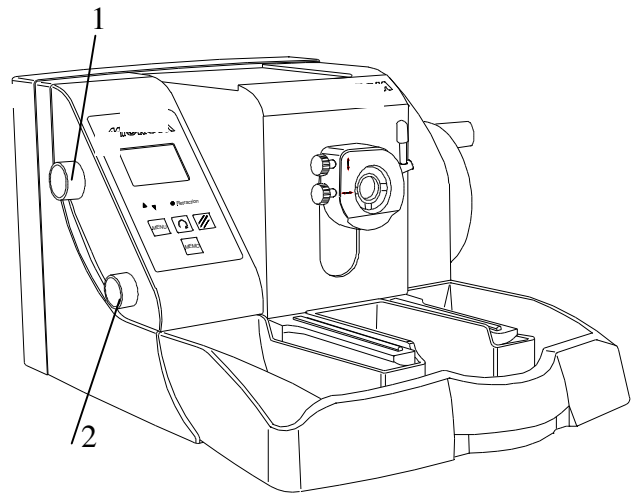

Fig. 13

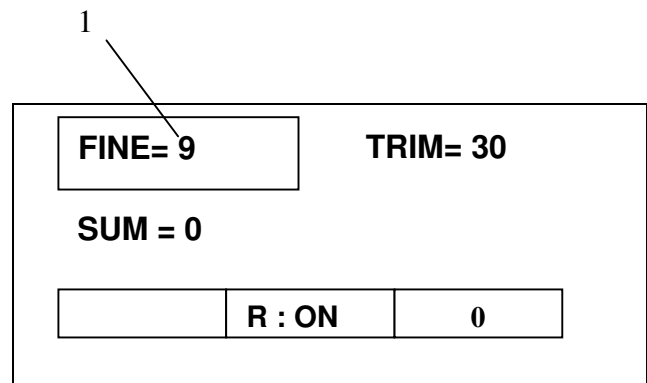

Fig. 14

3-5 CUTTING MOVEMENT AND RETRACTION

The cutting movement of the microtome is generated by turning the hand wheel.

- To start the cutting movement of the microtome, turn the hand wheel.
- As the specimen moves down, sectioning is carried out (cutting movement, fig. 15.2).
- Continue turning the hand wheel to bring the specimen back up (fig. 15.4).
- To protect the knife and specimen during return travel, the specimen is retracted (R).
- The yellow LED RETRACTION (fig. 16.1) lights up. If desired, the function <retraction> can be turned off.

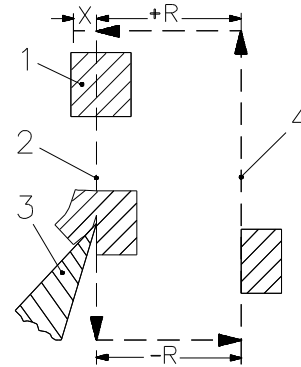

Fig. 15

X=selected section thickness
 1=specimen
 2=cutting movement
 3=knife
 4=return travel
 R=retraction

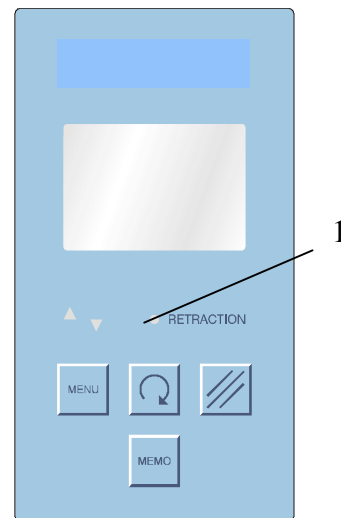

Fig.16

3-6 LOCKING AND UNLOCKING THE HANDWHEEL

The hand wheel is integrated into the housing. The position of the handle corresponds to the vertical position of the specimen.

- Turn the lever downwards in the direction of the arrow, to loosen the hand wheel lock (fig. 17).
- Turn the lever upwards, to lock the hand wheel.

The hand wheel can be locked in any position.



Warning:

For your personal safety, the hand wheel should be locked in the upper range of the vertical movement when changing specimens.

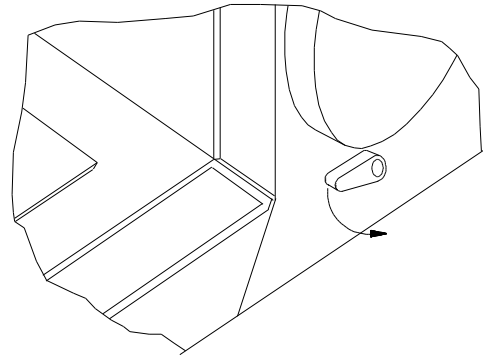

Fig. 17

3-7 SPECIMEN FEED

3-7-1 COARSE FEED AND SPEED FOR COARSE FEED

After changing the specimen or moving the knife or knife carrier, it is necessary to adjust the specimen to the knife edge again. This can easily be done by means of the specimen coarse feed and the defined trimming values.

For the fast forward and backward travel between specimen and knife edge, the microtome has a motorized coarse feed system.

- The specimen holder is moved to the front as long as the knob (fig. 18.2) for activating the coarse feed forwards, i.e. in the direction of the user, is turned.
- The feed speed is controlled via the turn angle. When the knob is only slightly turned forwards, the speed is slow. Turn the knob further towards the front, the speed will be higher.
- To move the specimen holder backwards, also turn the knob (Fig. 18.2) backwards, i.e. in the opposite direction of the user.
- In this case, the swing angle from the zero position on is also responsible for the coarse feed speed.
- In case the knob is kept in its maximum turn angle for more than two seconds, the specimen movement automatically moves in its rear end position after releasing the knob.
- Then the coarse feed motor turns off after having reached the rear end position.
- When the front end position of the specimen movement is reached, the red LED arrow on the operating panel (fig. 19.2) lights up.
- When the rear end position of the specimen movement is reached, the red LED arrow on the operating panel (fig. 19.1) lights up.
- Press the knob (fig. 18.2) to release trim feed with the selected value, even if the fine mode is active.

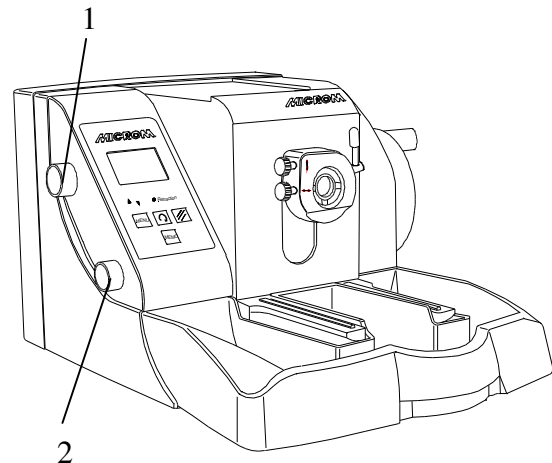

Fig. 18

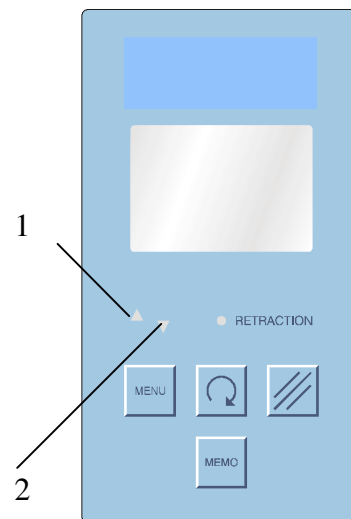

Fig. 19

3-8 MENU

3-8-1 DATE AND TIME

Via this menu, the current time as well as the current date can be set in the instrument.

- Press the menu button (fig. 20.1). The sub-menu (fig. 21) appears on the display.
- Select "Time and date" via the turning knob (fig. 22.1) and confirm it by pressing the knob.



Note:

The time can be shown constantly in the normal display mode via the scroll button.

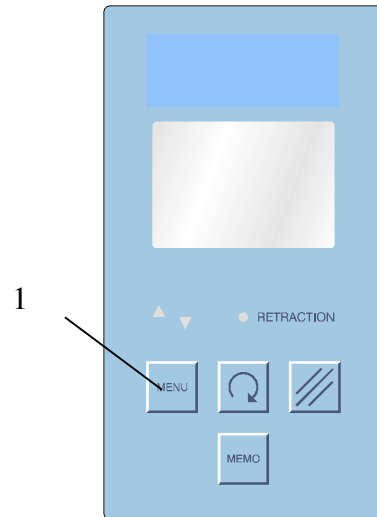

Fig. 20

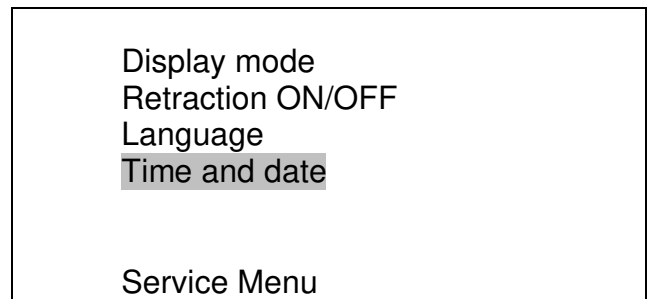

Fig. 21

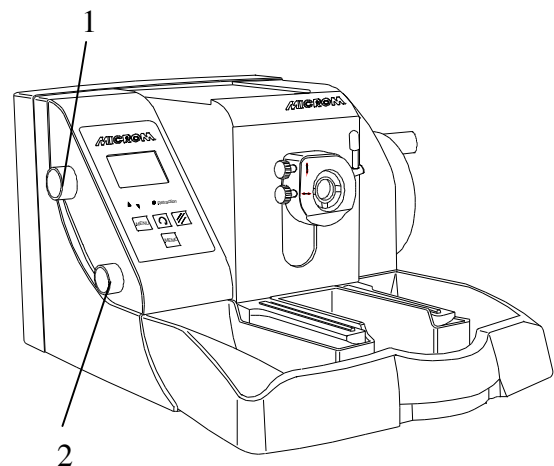

Fig. 22

3-8-2 SELECT THE DISPLAY MODE

Here the display mode can be selected. You can choose between the NORMAL and the LARGE display mode.

- The normal display mode (fig. 23) shows the selected fine and trim section thickness with additional status indications at the same time.
- The large display mode (fig. 24) only shows the currently active section thickness as a large number together with a symbol for the fine sectioning range or the trim sectioning range.
- Press the menu button (fig. 20.1). The sub-menu (fig. 25) appears on the display.
- Select the display mode via the turning knob (fig. 22.1) and confirm it by pressing the knob.

NORMAL

Section thickness display, FINE is currently active

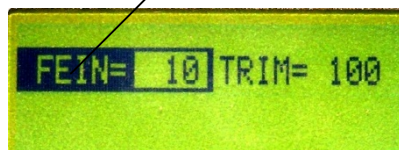

Mode display

Fig. 23

LARGE

Section thickness symbol for fine and trim



Section thickness indication in large numbers

Fig. 24

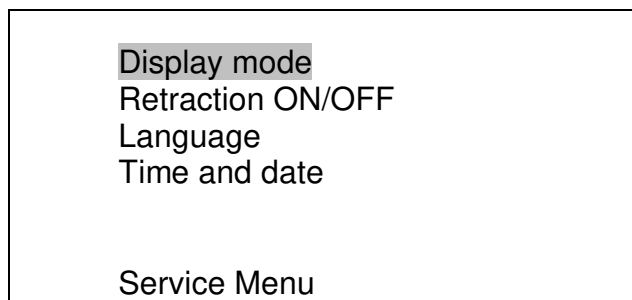

Fig. 25

3-8-3 TURNING OFF THE FUNCTION "RETRACTION"

If desired, the function "retraction" can be turned off.

- Press the menu button (fig. 27.1).
- Select submenu "Retraction" via the knob (fig. 28.1).
- Press the knob to confirm the selection.
- Turn the knob to select the desired function: R:ON or R:OFF.
- Press the knob to confirm the setting.
- The yellow LED RETRACTION, however, might still be on and goes off only after having passed from the return travel again to the cutting movement by means of the handwheel.
- To turn on again the function "Retraction", please proceed as described above.

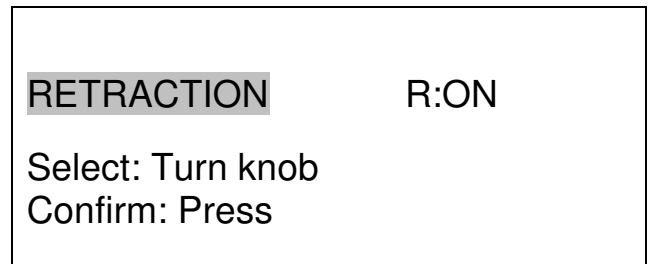

fig. 26

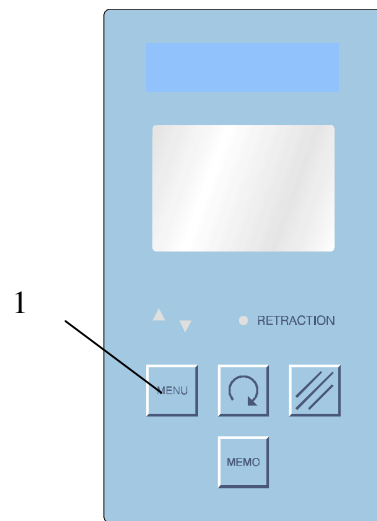

Fig. 27

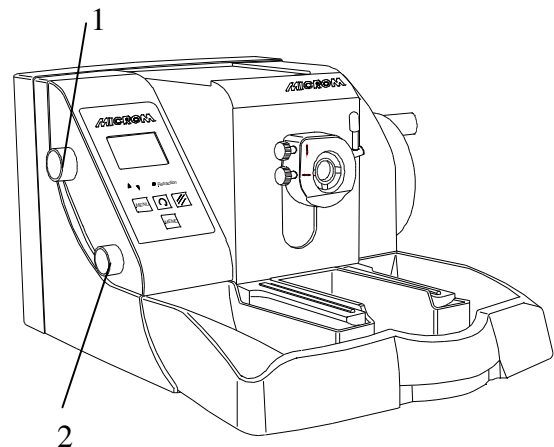

Fig. 28

3-8-4 SELECTING THE INDICATED LANGUAGE

The sectioning information on the display can be shown alternatively in five different languages.

- German
- English
- French
- Spanish
- Italian

- Press the menu button (fig. 30.1).
- In the sub-menu select "Languages" via the knob (fig. 31.1).
- Turn the knob to select the desired language.
- Press the knob to confirm the selected language.
- Press the menu button (fig. 30.1) to return to the NORMAL indication.
- The display (fig. 29) now shows the terms in the desired language.

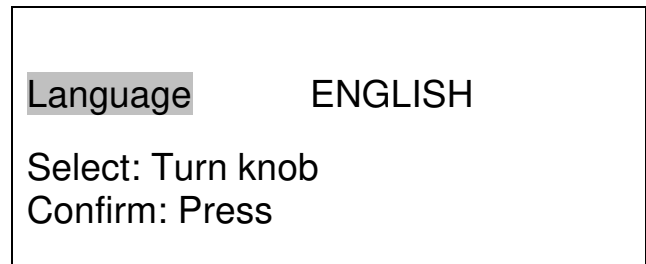

Fig. 29

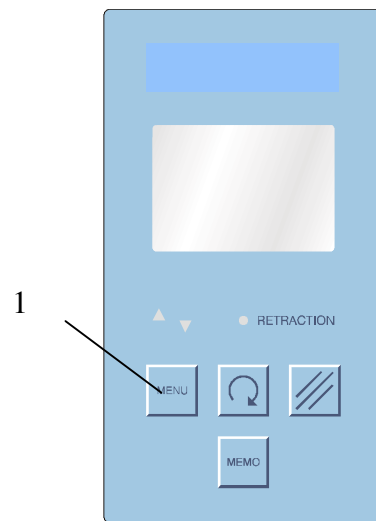

Fig. 30

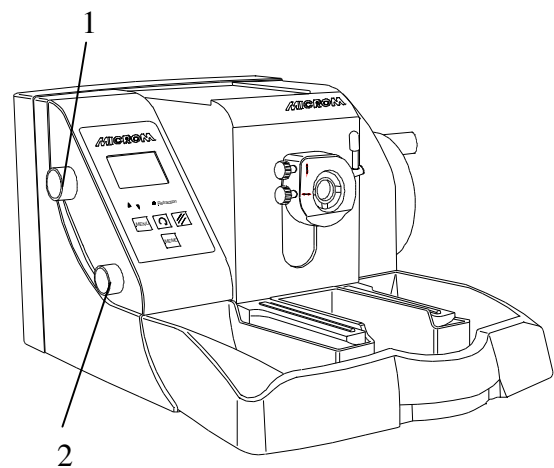

Fig. 31

3-9 ADAPTERS FOR SPECIMEN CLAMPING

3-9-1 ADAPTER, NON-ORIENTING

This adapter serves for the non-orienting fastening of the specimen clamps directly on the cylinder of the instrument.

3-9-2 ADAPTER, ORIENTING, SPECIMEN ORIENTATION

- Using the orienting adapter fasten the specimen clamps on the cylinder head. This allows the specimen to be aligned in relation to the knife.
- To bring the specimen into the desired position, turn the clamping lever (fig. 32.1) towards the front.
- This will loosen the specimen clamp and a rotation of 360° on the cylinder axis (Z axis) is possible.
- With the two orienting screws (fig. 32.2), the specimen clamp can be oriented 8° in each direction on the X axis and Y axis.
- After having oriented the specimen, turn the lever (fig. 32.1) upwards to fix the specimen clamp in its position before starting sectioning.
- When turning the orienting screws (fig. 32.2) a slight resistance can be felt in a specific position.
- This means that the clamp is aligned in a parallel way in relation to the cutting surface.

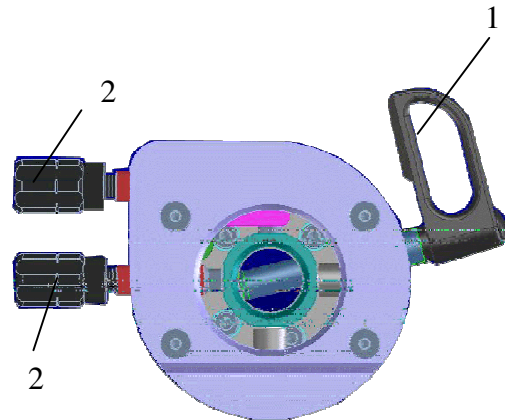

Fig. 32

3-9-3 CHANGING AND/OR CLAMPING SPECIMEN CLAMPS

The available specimen clamps are all clamped or removed in the same way.

- To change the specimen clamping system, press the clamping lever (fig. 33.1) downwards and pull it sideways.
- Now the specimen clamp can be pulled out to the front and can be replaced with another specimen clamping system.
- Insert the new specimen clamp into the cylinder head so that the clamping lever can be put through the hole of the adapter from the right side all the way through.
- Then align the specimen clamp by means of the orienting screws (fig. 33.2).
- Then press the clamping lever (fig. 33.1) upwards.

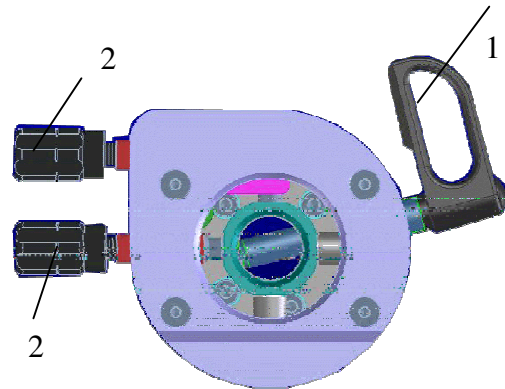

Fig. 33

3-9-4 READJUSTING SPECIMEN CLAMPS

Frequent use of the clamping lever (fig. 34.1) can lead to the fact that the specimen clamps cannot be clamped optimally anymore. If the necessary readjustments are not carried out, it might even be possible that the specimen clamp cannot be clamped (fig. 34.1).

- The clamping lever (fig. 34.1) should be in an almost upright position.
- To determine the clamping position of the clamping lever, adjust the inner screw (fig. 35.1) on the backside of the orienting adapter by means of an Allen key (size 3 mm).
- Turn the Allen key in a clockwise direction if no clamping was achieved at all or if the clamping position of the clamping lever is too high.
- If the clamping position of the clamping lever is too low, turn the Allen key in a counter-clockwise direction.

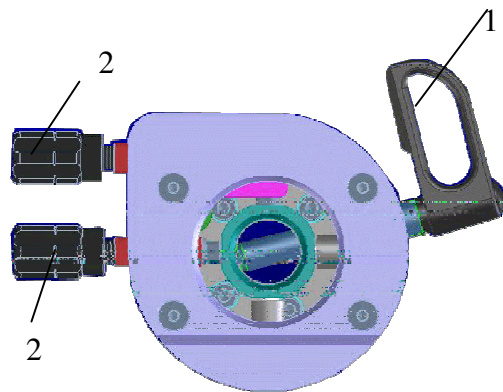

Fig. 34

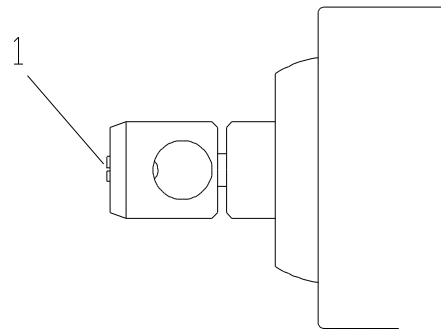

Fig. 35

3-10 SPECIMEN CLAMPING

To clamp specimens, different specimen clamping systems are available. With the orienting adapter it is simple to align the specimen properly in relation to the knife.

3-10-1 UNIVERSAL CASSETTE CLAMP

The universal cassette clamp (fig. 36) represents a quick change system.

- To insert or remove the cassette from between the fixed (fig. 36.1) and movable (fig. 36.2) jaws, pull the lever (fig. 36.3) to the front (in the direction of the arrow).



Note:

To achieve optimal clamping keep the locating surface of the cassette free of paraffin.

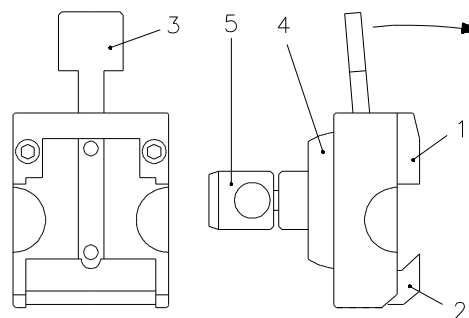

Fig. 36

3-10-2 UNIVERSAL CASSETTE CLAMP, ADJUSTABLE

- To insert and/or remove cassettes between the fixed jaw (fig. 37.1) and the movable jaw (fig. 37.2), move the lever (fig. 37.3) upwards.
- To adjust the size to a cassette size which is not according to the norm, use the nut (fig. 37.4).

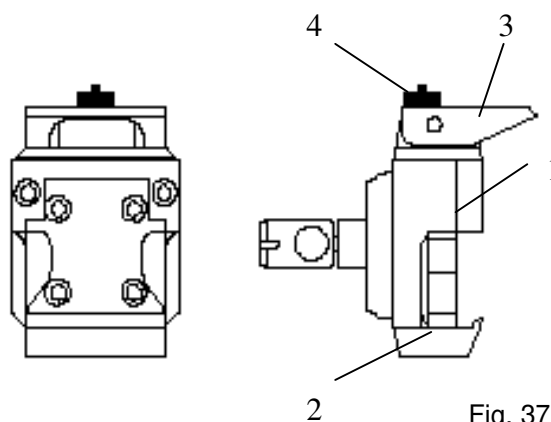

Fig. 37

3-10-3 STANDARD SPECIMEN CLAMP

The standard specimen clamp (fig. 38) is used for rectangular and square paraffin and plastic blocks.

- Insert the specimen against the fixed jaw (fig. 38.2) first.
- Then turn the knob (fig. 38.3) to tighten jaw (fig. 38.1).
- Fig. 38.4 and 38.5 show the orienting adapter, fig. 38.6 indicates the four holes for the fastening screws.



Note:

For the stability of the specimen, do not let it project over the clamping jaws too much.

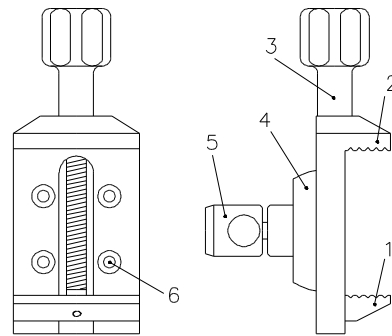

Fig. 38

The standard specimen clamp is supplied with two movable jaws, which are different in weight.

- The lightweight jaw is used in addition with inserts for round specimens.
- The heavier jaw is intended to be used together with the standard specimen clamp with no other holding elements.
- To exchange the clamping jaw, unscrew the clamping screw (fig. 38.3) to remove the jaw and replace it with the other one.

**3-10-4 INSERT FOR ROUND SPECIMEN,
V-INSERT AND V-DISTANCE PIECE**

To cut round specimens, the insert for round specimens (fig. 39.A) with defined diameters of 6, 15 and 25 mm (special sizes on request) or the V-insert (fig. 39.B) can be clamped into the standard specimen clamp.

- The pin (fig. 39.3), which fits into the lower clamping jaws (fig. 38.1), positions the insert precisely. The two springs (fig. 39.4) make it easy to remove the specimen from the inserts (fig. 39.1 and 39.2).
- To fasten the V-distance piece (fig. 39.C) on the fixed jaw (fig. 38.2) of the standard specimen clamp, the clamping screw (fig. 38.3) must be unscrewed from the spindle. Pull the spindle off the clamp.
- After having inserted the V-distance piece, insert the spindle again as well as the clamping screw (fig. 38.3).

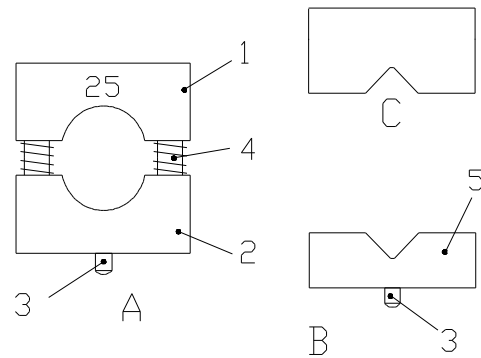

Fig. 39

3-10-5 FOIL CLAMP

The foil clamp (fig. 40) is a clamping system for foils or thin specimens.

- To insert the specimen, loosen the three clamping screws (fig. 40.5) slightly and push the movable jaw (fig. 40.2) sideways against the two springs (fig. 40.3).
- The specimen is kept in place by the springs, however, its position can be changed. Turn the three clamping screws (fig. 40.5) to clamp the specimen tightly.
- When using an orienting adapter with the instrument, first insert the enclosed graduated ring into the orienting adapter by means of the pin. With the graduated ring the orientation in X-/Y-direction is annulled.
- However, it is possible to turn in Z-axis 60° in either direction.
- Then insert the foil clamp.
- According to the various specimens, it might be helpful to use in addition Microm's sandwich supporting material (cat. no. 176010) on the right and left side between specimen and clamping jaw.

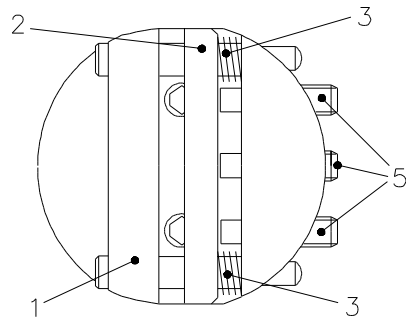

Fig. 40

3-10-6 SEGMENT ARC AND UNIVERSAL SPECIMEN HOLDER

The segment arc and universal specimen holder are highly suitable for the clamping of small specimens embedded in plastic (fig. 41).

- The specimen is inserted in the holder (fig. 41.1) and clamped by means of the screw (fig. 41.2) with the hex head wrench (fig. 41.3).
- Then the holder together with the specimen is put into the segment carrier (fig. 41.5), where the holder can be turned 360°.
- Thus, the specimen can be aligned as required.
- Then, the holder is clamped by means of the screw (fig. 41.4) in the selected position.
- The carrier (fig. 41.5) can be moved on the base (fig. 41.6). In this way, the surface of the specimen can be oriented parallel to the knife.
- The knurled screw (fig. 41.7) is used to tighten the carrier (fig. 41.5) on the base (fig. 41.6).

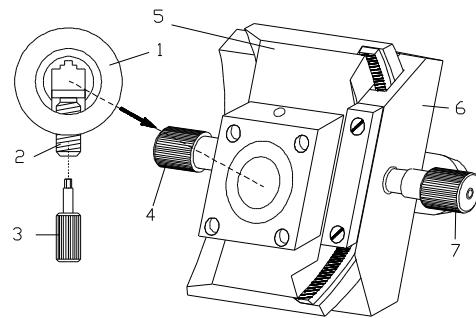

Fig. 41

3-11 KNIFE CARRIERS



Hazard of hand injuries:

Due to moving parts in connection also with the microtome knife, a danger area arises, which might lead to hand injuries in case of non-compliance with the safety features of the microtome and when disregarding the instruction manual.

The knife carriers of the microtome are easy to use, can be moved sideways and are equipped with knife guards for user safety while adjusting knife and specimen.

3-11-1 DISPOSABLE BLADE CARRIER ER

The disposable blade carrier ER is designed to take all commercially available high and low profile blades.

Using low profile blades:

- Insert the blade into the slot behind the clamping plate (fig. 42.5).
- For this, turn the clamping lever (fig. 42.7) towards the front. Swing the bracket with scale (fig. 42.4) to the front.
- Loosen the clamping lever (fig. 42.7) and, if necessary, slightly push the lower part of the clamping plate (fig. 42.5) as well.
- Insert the blade on the rail (fig. 42.3) and push it from the side to the middle.
- Afterwards, return the clamping lever (fig. 42.7) upright, thus locking the blade in position.
- The bracket (fig. 42.4) is provided with a scale.
- After loosening the clamping lever (fig. 42.2) and after having moved the bracket (fig. 42.4) upwards, move the blade together with the entire upper part without having to loosen the blade clamping.
- This way, the entire cutting length of the blade can be used.
- Then tighten the clamping lever (fig. 42.2).
- The lever (fig. 42.2) can be removed by pulling it off towards the side.

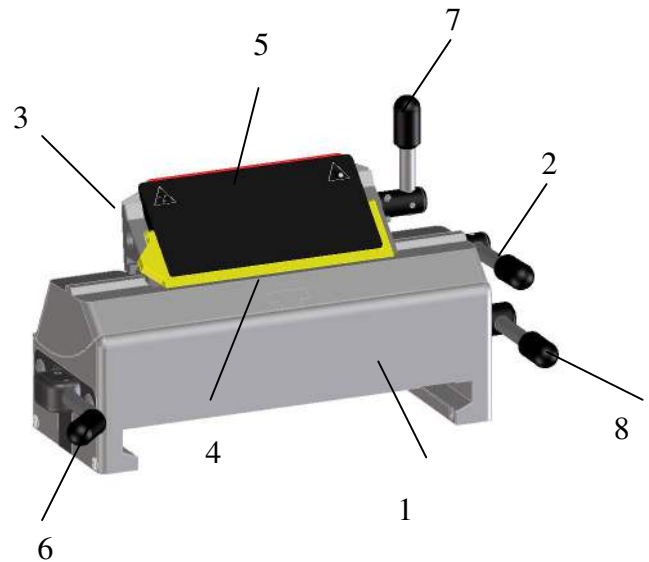

Fig. 42

Using high profile blades:

When using high profile blades, first remove the spacer strip (fig. 42.3).

- For this, turn the clamping lever (fig. 42.7) to the front until the stop.
- Then press the stop pin into the knife carrier and further turn the clamping lever (fig. 42.7).
- Pull off the clamping lever (fig. 42.7) and remove the clamping plate (fig. 42.3).
- Insert the clamping plate and clamping lever again.
- Push the stop pin into the knife carrier and turn the lever into an upright position.

Clearance angle adjustment:

- The clearance angle between cutting edge and specimen can be shifted and adjusted to the respective requirements of the tissue to be sectioned.
- Loosen the clamping lever (fig. 42.8) on the right side of the knife carrier and move the upper part (fig. 42.9) of the knife carrier on the base (fig. 42.1).
- The adjusted clearance angle can be read on the scale.
- Then turn the clamping lever (fig. 42.8) upwards to lock in the new clearance angle.
- The clamping lever for the angle adjustment can be pulled off after a correct angle setting to avoid that the angle is "reset" unintendedly.



Note:

By experience, usable cuts are only achieved at a clearance angle of 10° or more.

Moving the knife carrier on the console:

- Loosen the clamping lever (fig. 42.6) on the left side of the knife carrier, to move the carrier forwards and backwards on the dovetail guide.
- This allows a rough adjustment of knife to specimen.

Protection against injury:

- A bracket (fig. 42.4) on the clamping plate can be moved upwards over the blade for the protection against injury.

3-11-2 DISPOSABLE BLADE CARRIER E

Inserting the blade:

- The disposable blade carrier E is designed to take all commercially available high and low profile blades.
- Insert the blade into the slot behind the clamping plate (fig. 43.5).
- When using high profile blades, first loosen the two screws (fig. 43.9) and remove the spacer strip (fig. 43.3).
- Turn the clamping lever (fig. 43.7) to the front.
- Swing the bracket with scale (fig. 43.4) to the front.
- Loosen the clamping lever (fig. 43.7) and, if necessary, slightly press the lower part of the clamping plate as well.
- A small gap between rail (fig. 43.3) and clamping plate (fig. 43.5) can be seen.
- Insert the blade on the rail (fig. 43.3) and push it from the side to the middle.
- Afterwards, return the clamping lever (fig. 43.7) upright, thus locking the blade in position.
- The bracket (fig. 43.4) is provided with a scale.
- After loosening the clamping lever (fig. 43.7) and after having moved the bracket (fig. 43.4) upwards, move the blade together with clamping plate (fig. 43.5) according to the scale by means of the knife guard to the left or right side.
- This way, the entire cutting length of the blade can be used. Then press the clamping lever (fig. 43.7) upwards.
- The levers (fig. 43.7 and 43.3) can be removed by pulling them off towards the side.
- The lever (fig. 43.7) can also be used on the left side. This way, the blade can be clamped with the left hand.

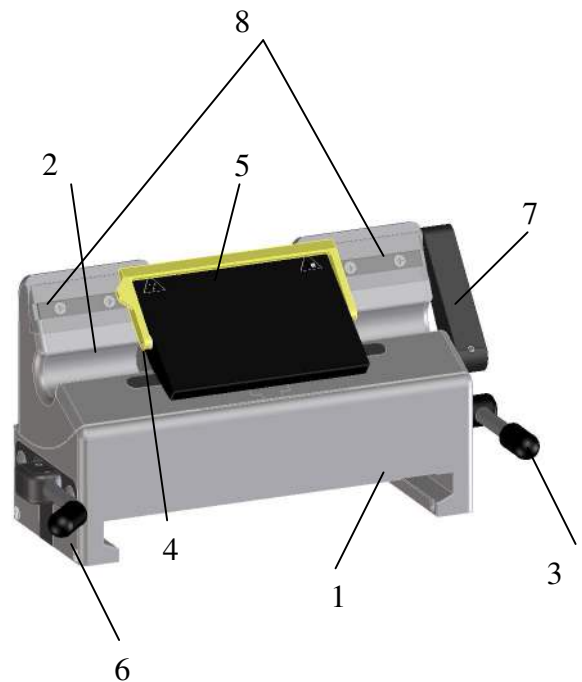

Fig. 43

Clearance angle adjustment:

- The clearance angle between cutting edge and specimen can be shifted and adjusted to the requirements of the tissue to be sectioned.
- Loosen the clamping lever (fig. 43.3) on the right side of the knife carrier and move the upper part of the knife carrier (fig. 43.2) on the base (fig. 43.1).
- The adjusted clearance angle can be read on the scale.
- Then turn the clamping lever (fig. 43.3) upwards to lock in the new clearance angle.



Note:

By experience, usable cuts are only achieved at a clearance angle of 10° or more.

- If the clamping lever (fig. 43.3) is loosened, the upper part of the knife carrier can be moved 1 cm to the left or right side.
- This way, the cutting edge can optimally be used.
- The clamping lever for the angle adjustment can be pulled off after a correct angle setting to avoid that the angle is "reset" unintendedly.

Moving the knife carrier on the console:

- Loosen the clamping lever (fig. 43.6) on the left side of the knife carrier, to move the carrier forwards or backwards on the dovetail guide.
- This allows a rough adjustment of the knife to the specimen.

Protection against injury:

- A bracket (fig. 43.4) on the clamping plate can be moved upwards over the blade for the protection against injury.

3-11-3 KNIFE CARRIER C

- To insert the knife, the clamping screws (fig. 44.3) must be unscrewed slightly so the knife can be pushed in from the side.
- The height of the knife is adjusted with the two knurled nuts (fig. 44.6) and the bar (fig. 44.7).
- If the cutting zone of the knife cannot be used anymore, it can be moved over its entire length to the left and right side by loosening the clamping screws.
- This allows an optimal use of the entire knife edge.



Caution:

When clamping the knife, please tighten the two clamping screws (fig. 44.3) simultaneously.

Clearance angle adjustment:

- The clearance angle between cutting edge and specimen can be shifted and adjusted to the requirements of the tissue to be sectioned.
- Loosen the clamping lever (fig. 44.4) on the right side of the knife carrier and move the upper part of the knife carrier (fig. 44.2) on the base (fig. 44.1).
- The adjusted clearance angle can be read on the side scale.
- Then turn the clamping lever (fig. 44.4) upwards to lock in the new clearance angle.
- The clamping lever for the angle adjustment can be pulled off after a correct angle setting to avoid that the angle is "reset" unintentionally.



Note:

By experience, usable cuts are only achieved at a clearance angle of 10° or more.

- If the clamping lever (fig. 44.4) is loosened, the upper part of the knife carrier can be moved 1 cm to the left or right side.
- This way, the cutting edge can optimally be used.

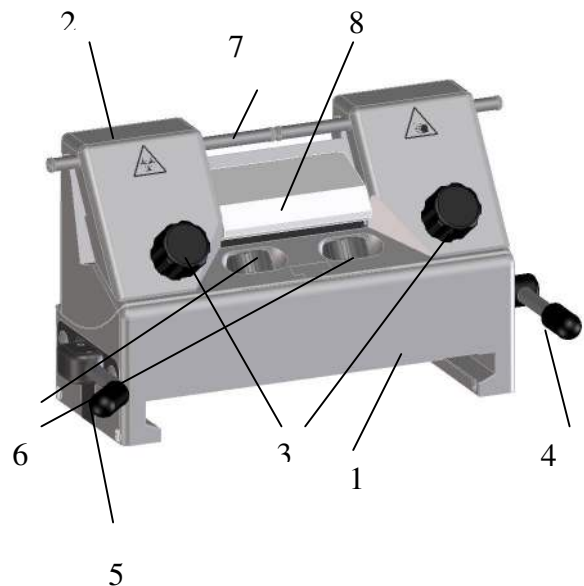

Fig. 44

Moving the knife carrier on the console:

- Loosen the clamping lever (fig. 44.5) on the left side of the knife carrier to move the carrier forwards and backwards on the dovetail guide.
- This allows a rough adjustment of knife and specimen.

Protection against injury:

- The knife carrier is equipped with two knife guards (fig. 44.7) which can be moved sideways.
- These knife guards should be pushed together in the middle while adjusting knife or specimen.
- This reduces the danger of injury considerably.

Central clamping plate:

- The knife is clamped and stabilized in the cutting zone by the central clamping plate (fig. 44.8) - exactly where the highest cutting forces are applied.

Two types of clamping plates are available for the knives:

clamping plate c for c-knives,
clamping plate d for d-knives.

Fig. 45 shows schematically the angles on the cutting edge profiles of c- and d-knives.

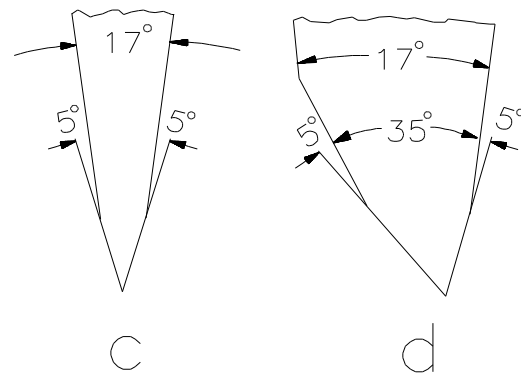

Fig. 45

3-11-4 READJUSTING KNIFE CARRIERS

Frequent use of the clamping levers can lead to the fact that the knife carriers cannot be clamped optimally anymore. If the necessary readjustments are not carried out, it might even be possible that the knife carriers cannot be clamped anymore.

- If the clamping lever does not allow a sufficient clamping, the clamping can be adjusted as follows:
- For this, loosen the set screw (fig. 47.1) on the lower side of the knife carrier.
- Insert a pin into one of the holes of the brass screw (fig. 47.2) and turn the brass screw.
- When the clamping is to be strengthened, turn the brass screw (fig. 47.2) to the right side.
- When the clamping is to be loosened, turn the brass screw to the left side.
- Before inserting the knife carrier again, first tighten the set screw (fig. 47.1).
- Afterwards, push the knife carrier onto the consoles and check the clamping function.
- If necessary, repeat the above-mention process.

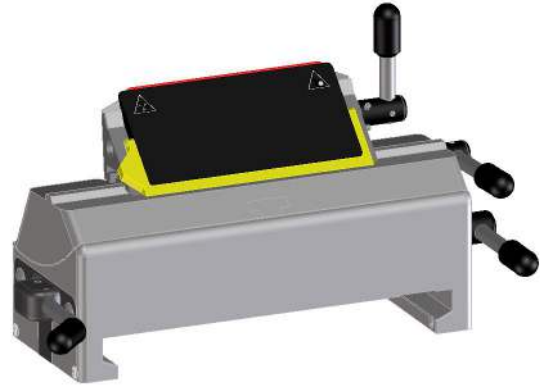

Fig. 46

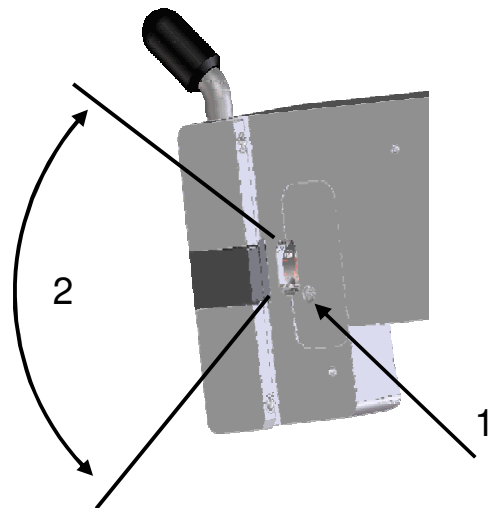

Fig. 47

**3-12 SECTION WASTE TRAY WITH
INTEGRATED ARM REST**

The section waste tray with integrated arm rest can easily be cleaned.

- The section waste tray surrounds the knife carrier area and allows non-tiring working with the microtome.
- It can be easily removed to the front at any time.

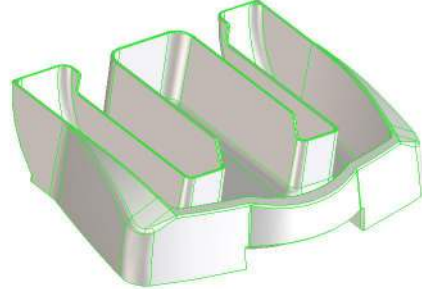

Fig. 48

3-13 MEMORY FUNCTION

The memory function is used to quickly find again the same position for the first cuts.

This function can only be used on condition that blocks, which have been embedded in the same molds, are cut. The blocks must have almost the same height.

- To set the so-called "first-cut-position", move the specimen clamping via coarse feed function forwards until the specimen is almost situated at the knife edge.
- To store this position, press the button MEMO (fig. 49.1) for approx. 1 sec.
- "Pos. stored" is then briefly shown on the display.
- Then proceed with the routine work (trimming, first-cuts, fine sectioning).
- When the work on the block has been finished, briefly press the MEMO button (fig. 49.1). The specimen clamping then moves backwards,
- Unclamp the specimen and insert a new specimen.
- The specimen surface is now in the "first-cut-position".

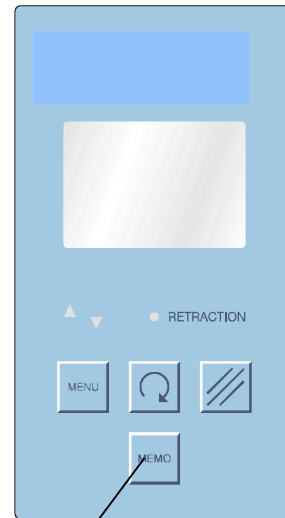

1

Fig. 49



Warning:

The stored cutting position can only be used effectively when blocks with the same height are cut. Neither adjustments on the knife carrier must be made nor must the knife carrier be moved on the consoles.



Warning:

When moving the knife carrier on the dovetail guide, a new first-cut-position must be selected as otherwise the danger of a collision with injuries might arise.

- When turning on the instrument later again, the first-cut-position must be defined and stored again for safety reasons.

3-14 LARGE FIELD MAGNIFIER

The large field magnifier (fig. 50.1) is for looking at section production.

- The light is connected to the power outlet with the power cord (fig. 50.2) and turned on and off with the switch (fig. 50.3).



Caution:

Before using the large field magnifier for the first time, please check if the voltage conditions at the installation site comply with the power requirements and frequency mentioned on the supply unit of the magnifier.

Installing the large field magnifier on the microtome:

- Please use the enclosed fastening elements to attach the magnifier to the microtome.
- Remove the cover plate from the upper side of the instrument.
- Remove the front plastic caps from the upper side of the housing.
- If there are no drilled holes in the housing, it must be replaced with a new one with drilled holes.
- Fasten the peg (fig. 50.4) to the plate (fig. 50.6) with the screw (fig. 50.7).
- Carefully introduce the four sleeves (fig. 50.8) into the drilled holes with the screws (fig. 50.5).

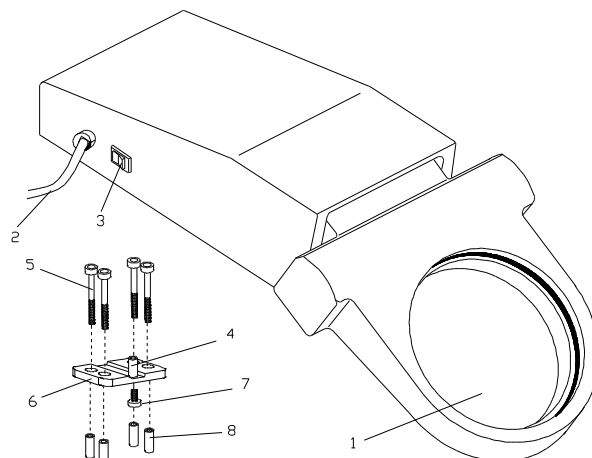

Fig. 50



Warning:

Please note that the sleeves do not fall into the interior of the microtome!



Note:

Make sure the plate (fig. 50.6) is mounted in a way that the peg (fig. 50.4) is closer to the front of the microtome!

- Put the plate (fig. 50.6) on the sleeves and fasten it to the microtome with four screws (fig. 50.5).
- A movable plastic socket that should be put on the peg (fig. 50.4) is on the under side of the magnifier.
- The magnifier can be adjusted forwards and backwards for the most favorable viewing position.
- If the large field magnifier is not used, slightly raise it and turn it sideways on the peg.

PART 4 WORKING WITH THE MICROTOME

4-1 SECTIONING INSTRUCTIONS

To cut usable sections, the following points are of utmost importance:

Condition of the knife edge:

- Only use a sharp knife!
- If the cutting edge is blunt, move the knife horizontally either to the right or left side to continue working with the sharp area of the cutting edge, or have the knife resharpened.
- For optimal sectioning, front and back of the knife must be clean.
- Especially paraffin waste must be removed thoroughly!

Setting the cutting angle:

Inclination of the knife in relation to the block surface

Each microtome knife has a so-called facet cut resulting from the fact that when producing a knife or when resharpening the blade, the rear side of knife is increased in order not to cut down the entire knife surface. This way, two facet surfaces are generated on the blade forming a larger angle between themselves compared with the main surfaces of the knife.

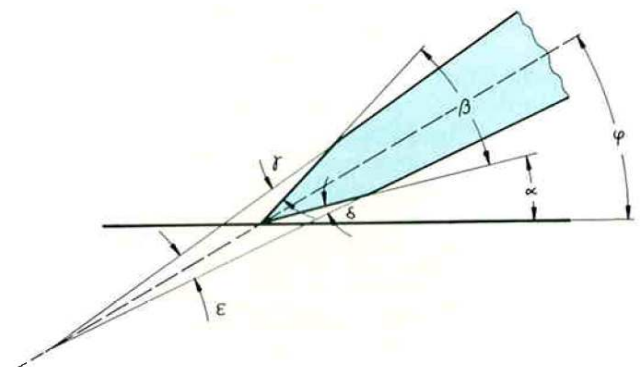

Fig. 51

According to DIN 6581, there are following angles on a microtome knife:

1. clearance angle α
2. wedge angle β
3. upper sharpening angle γ
4. lower sharpening angle δ
5. blade angle ϵ
6. angle of inclination ϕ

During practical work the angle of inclination is our so-called clearance angle, i.e. the angle between lower facet surface and block surface. The optimal inclination slightly differs for each knife, as the wedge angles as well as especially the facet angles on the individual knives are not absolutely identical.

The knife must never be placed too flat. This way, the blade does not cut into the block at all. Only the rear side slides over the sectioning surface (see opposite figure).

An inclination, which is too steep, is also unfavorable as the knife might vibrate too much while sectioning. The so-called "chatters" appear on the block surface as well as on the sections. These chatters are parallel stripes in relation to the knife edge having negative effects on the microscopical evaluation of sections.

Between these two limit cases, the correct knife inclination must be determined. A clearance angle between facet angle and block surface of approx. 5° is normal.



Caution:

Different microtome producer use different scalings for their clearance angle adjustment, resulting from different calculation bases. The clearance angle might refer to the facet surface or to the angle between knife main surface and block surface. As the facet has a divergence from the knife main surface of approx. 5° , the difference is approx. 5° . Set the correct angle on Microm instruments at 10° .

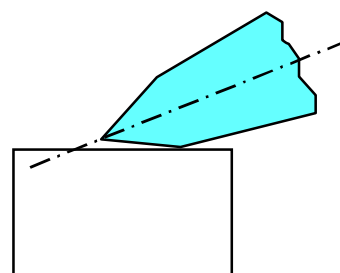

Fig. 52

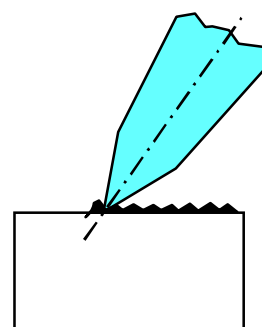

Fig. 53

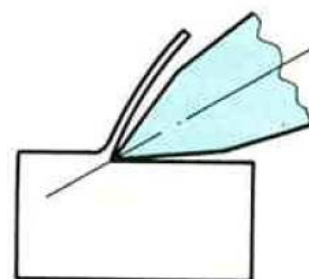

Fig. 54

4-2 HOW TO AVOID MALFUNCTIONS

Specimen preparation:

- When preparing specimens, be sure that a suitable embedding medium, fixation, dehydration and infiltration time are chosen.

Specimen temperature:

- Sectioning is carried out at ambient temperature (excluding frozen sections).
- If the temperature is too high, the paraffin softens. Therefore, avoid heating paraffin specimens by direct exposure to sunlight or other near sources of heat.

Tightening the clamping screws:

- Tighten all clamping screws and clamping levers on the knife carrier, specimen holder and specimen orientation.

Selection of the knife:

- Carefully select the required knife material and profile.

Adjustment of the knife:

- Take care to adjust the proper clearance angle of the knife: 5 - 7° for glass knives. For diamond knives ask the knife manufacturer.
- Select a clearance angle adjustment of 5 - 15° according to the facet angle. Typically, adjust an angle of 10 - 12 °.
- Take care to adjust knife height.

Cutting speed:

Take care to select proper cutting speed.

- General Rule: The harder the material, the slower the cutting speed!

Trimming:

- Take care in bringing knife and specimen together.

4-3 POSSIBLE SOURCES OF ERRORS – CAUSE AND REMOVAL

Problem	Cause	Removal
Thick-thin-sections	<ul style="list-style-type: none"> – Blunt knife/blade. – Knife angle, therefore, unfavorable clearance angle. – Insufficient clamping on specimen clamping and/or knife carrier. 	<ul style="list-style-type: none"> – Move knife and/or insert a new one. – Try clearance angle adjustments, until an optimal angle can be found. – Check all screw and clamping connections on specimen clamping and knife carrier. Tighten them, if necessary.
Compressions	<ul style="list-style-type: none"> – Blunt knife/blade. – Specimen too warm. – Unfavorable clearance angle. – Cutting speed too high. 	<ul style="list-style-type: none"> – Move knife and/or insert a new one. – Cool specimen. – Try clearance angle adjustments until an optimal angle can be found. – Turn handwheel slower.
"Chatter" on sections	<ul style="list-style-type: none"> – Cutting speed too high. – Unfavorable clearance angle. – Insufficient clamping on specimen clamping and/or knife carrier. 	<ul style="list-style-type: none"> – Turn handwheel slower. – Try clearance angle adjustments until an optimal angle can be found. – Check all screw and clamping connections on specimen clamping and knife carrier. Tighten them, if necessary.
No feed is carried out anymore, and therefore, no sections are produced	<ul style="list-style-type: none"> – Front end position has been reached. – Coarse feed wheel is blocked. 	<ul style="list-style-type: none"> – Move specimen backwards by turning the coarse feed wheel. – Remove blockade on coarse feed wheel.
Tight handwheel - partly - during the entire movement	<ul style="list-style-type: none"> – Debris and section waste between microtome and base plate. – Dirty link block. 	<ul style="list-style-type: none"> – Remove section waste and clean microtome. – Contact a service technician.
Instrument cannot be turned on	<ul style="list-style-type: none"> – Power cord not correctly connected – Defective main fuse 	<ul style="list-style-type: none"> – Check power cord – Check/replace the fuses in the mains plug unit



Note:

In case of malfunctions and/or service work, please turn off the instrument and contact your local dealer.

PART 5 MAINTENANCE AND CARE

5-1 CLEANING AND CARE

Cleaning and care of the microtome should be carried out daily. Please proceed as follows:

- Lock the hand wheel.
- Remove the knife from the knife carrier. Clean it and store it in a knife case!
 - Remove section waste by using a dry brush.
 - Pull the section waste tray towards the front and dispose of the section waste according to your specific lab regulations.



Caution:

Never put the knife with the cutting edge upward on the table!!

- Loosen the clamping lever on the left side of the knife carrier and pull the knife carrier towards the front.
- Clean the operating controls and the surfaces of the knife carrier, especially the space where the knife carrier is installed.
- Clean the consoles, hand wheel, coarse feed wheel, specimen clamping system, specimen orientation as well as the base plate and housing.



Note:

Mild domestic cleaners can be used to clean the microtome. Do not use aggressive cleaners or solvents, as the paint and plastic parts can be affected.



Warning:

When getting in contact with cleaning agents or paraffin repellents, e.g. Para Gard, the surface of the cover ribbon behind the specimen clamping might be affected. For this reason, please note that the cover ribbon does not get in contact with these agents when cleaning the housing, knife carrier or the base plate.

- Before starting sectioning, instrument, knife carrier and section waste tray should be treated with a commercially available paraffin repellent.

Note:

This medium considerably reduces the adhesive force of paraffin waste on the individual parts of the microtome.

5-2 MAINTENANCE

Annual routine maintenance:

To secure section quality and functioning of the microtome, it is recommended that a **routine maintenance** be performed by a trained service technician **once a year**.

Service contract:

Thermo Fisher Scientific Microm International GmbH offers a service contract which guarantees that your instrument is always in perfect condition. For more information, please contact the nearest Thermo Scientific sales office.



Note:

We strongly recommend to not carry out repair by yourself. All warranties and guarantees would then be null and void! Repair work must only be carried out by an authorized service technician.

5-3 REPLACEMENT WORK

Replacing the fuses:

The two fuses of the instrument are placed on the rear side of the instrument beside the main switch (fig. 55.1).

- To replace the two fuses, turn off the main switch of the instrument and unplug it.
- Then open the cover (fig. 55.2) on the right side (see arrow) by means of a flat screwdriver.
- Pull out the fuse holders, each of which is marked with an arrow, and replace the fuses with new ones.

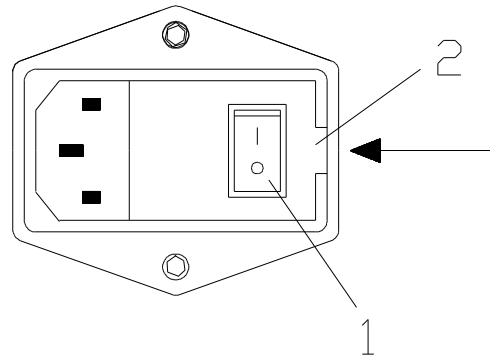

Fig. 55

Rating of fuses:

For power requirements 220 – 240 V:
- 2 fuses 200 mA

For power requirements 100 – 120 V:
- 2 fuses 400 mA

PART 6 CONDITIONS FOR THE TRANSPORTATION OF THE INSTRUMENT

6-1 RETURNING THE INSTRUMENT FOR REPAIR OR ROUTINE MAINTENANCE

Repair or maintenance work are normally carried out at the site of installation. If this is not possible for some specific reasons, the instrument can be returned to Thermo Fisher Scientific Microm International GmbH. The contact address can be found at the beginning of this instruction manual.

- To guarantee a trouble-free function of the instrument after transportation, please note the below-mentioned measures for transportation preparations.
- In addition, the conditions for storage and transportation as mentioned in part 2-3 must be observed during the entire transportation.



Biohazard:

Please also note the precautionary measures described in our safety precautions concerning biological hazards!

Measures for taking out of operation:

- Lock the hand wheel.
- Turn off the main switch of the instrument.
- Remove knife or blade and store it in a safe place.
- Remove the section waste tray.

In case the instrument or parts of the instruments are sent to Thermo Scientific Microm or to one of its representatives in such a condition that there might be a potential danger of infection, the instrument and/or the part(s) will be returned to the customer in an unrepaired status. Costs for this are to be borne by the customers.

For transportation outside closed buildings, please observe the following measures:

- Lock the handwheel.
- Turn off the main switch of the instrument.
- Remove knife or blade and store it in a safe place.
- Remove the section waste tray.

- To lift the instrument, use the recessed grip on the lower rear side of the instrument and the guidance for the knife carrier.
- During transportation, do not carry the instrument on the handwheel handles. Danger of being injured!
- Pack the instrument into the original packing as it offers best pre-conditions for transportation without damage.

Caution:

Any shipping of the instrument requires original packaging materials! Damages caused by shipping with non-conform packaging are not covered by the manufacturer warranty! Any damage repairs resulting in non-conforming package are fully charged to the sending party. We reserve the right depending on seriousness of damage NOT to repair.

To order original packaging materials, please contact Thermo Fisher Scientific or your local, by Thermo Scientific authorized, dealer.

Caution:

The user must care for a clean and safe condition of the instrument when returning it to an appropriate service provider.

Note:

If the original packaging is no longer available, please contact your local Thermo Scientific representation.

6-2 DISPOSAL OF THE INSTRUMENT AFTER FINAL SHUTDOWN

After the final shutdown of the instrument, we recommend to contact a local recycling company for the disposal according to the national applicable regulations.

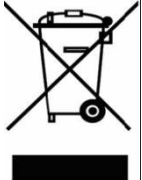

To be applied in the countries of the European Union and other European countries with a separate collecting system within the waste management.

The marking of the product and/or the respective literature indicates that, after its final shutdown, it must not be disposed of together with ordinary domestic waste.

- Please dispose of your instrument separately from other waste to not harm our environment and/or human health by uncontrolled waste disposal.
- Recycle your instrument to support the sustainable recycling of material resources.
- **Industrial users** should contact their suppliers and observe the conditions of the contract. This product must not be disposed of together with other commercial waste.
- **Please contact your supplier!!**